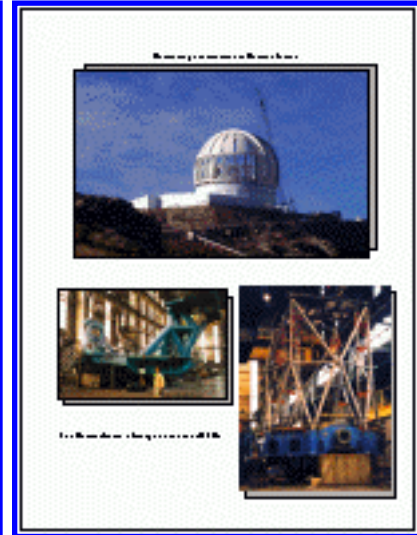
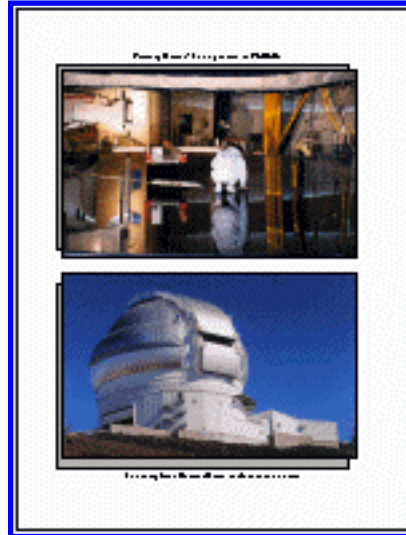


## June 1998 - Number 16



## Table of Contents

- [A Note from the Director](#)
- [From Australia](#)
- [Project Status Update](#)
- [Gemini Science Operations Plan](#)
- [Gemini WFS CCDs and Controllers](#)
- [US Gemini Project Office Report](#)
- [UK Gemini Project Office Report](#)
- [Chilean Gemini Project Office Report](#)
- [Brazilian Gemini Project Office Report](#)
- [News from AURA](#)

- [Released Documents](#)
- [Staff Changes](#)

---

Ruth A. Kneale / [web@gemini.edu](mailto:web@gemini.edu) / June 1998



# NEWSLETTER

Issue 16

June 1998

**GEMINI**  
8-Meter Telescopes Project



## *A Mirror Arrives; The Partnership Grows*

### Table of Contents

- Project Status Update
- Gemini Balance Operating Plan
- Gemini WFB CCD and Controllers
- Gemini Support Capability Requirements
- National Project Office Reports
- News from AURA
- Staff Changes
- Released Documents



United States • United Kingdom • Canada • Australia • Chile • Argentina • Brazil

Ruth A. Kneale / [web@gemini.edu](mailto:web@gemini.edu) / June 1998

Primary Mirror #1 being tested at REOSC.

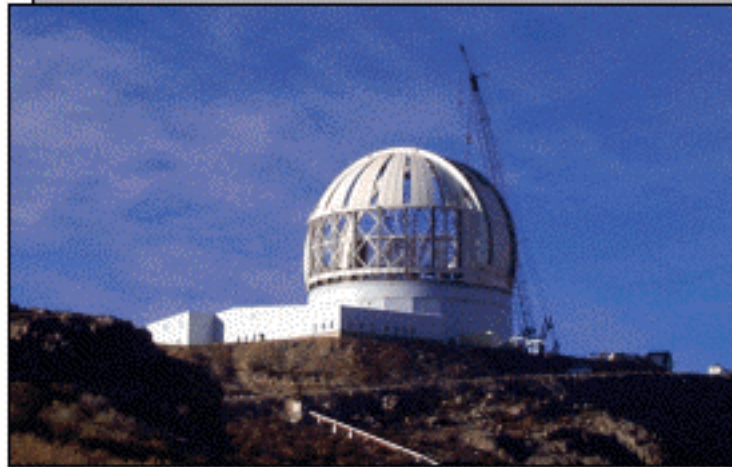


The completed Gemini North enclosure and dome.

---

Ruth A. Kneale / [web@gemini.edu](mailto:web@gemini.edu) / June 1998

Continuing construction at Gemini South



The Gemini South telescope structure at NFM.



---

Ruth A. Kneale / [web@gemini.edu](mailto:web@gemini.edu) / June 1998



Construction of the H50 Base Facility in Hawaii



## GEMINI 8-Meter Telescope Project

*THE GEMINI 8-METER TELESCOPES PROJECT is an international partnership managed by the Association of Universities in Research in Astronomy under a cooperative agreement with the National Science Foundation.*

550 N. Cherry Avenue  
P.O. Box 26732

Tucson, Arizona 85726-6732

Phone: (520) 318-3545

Fax: (520) 318-3550

em ail: [geminiv@gemini.edu](mailto:geminiv@gemini.edu)

World-Wide Web: <http://www.gemini.edu/>

Video Conferencing: (520) 384-1118 & 384-1119

Edited by Ruth Kneale

United States • United Kingdom • Canada • Australia • Chile • Argentina • Brazil

Ruth A. Kneale / [web@gemini.edu](mailto:web@gemini.edu) / June 1998

## From the Director

In June 1993, I wrote an article for this newsletter discussing Gemini's choice of a ULE meniscus mirror. I wrote, *"These mirrors have uniform thickness, hence uniform mass/unit area, and a uniform stiffness/unit area, so we can use simple air pressure to support 80% of the mirror weight without noticeably changing the mirror figure. Consequently, the residual control forces only have to be accurate to 1 part in  $10^3$  and have a dynamic range of  $\pm 500$  Newtons, well within the capabilities of commercial load cells. How successful can these support systems be?"* [Project Scientist's Outlook, Issue #5]. Though we are a little under four months away from actually using one of these mirrors on Mauna Kea, an important milestone was reached on March 18, 1998 when our first polished primary arrived in Hawaii. This mirror was polished and tested using our support concept and is well within our specifications; as I wrote in 1993, *"by concentrating on local smoothness and correcting any large scale errors with the active support system, the polishers [could produce] a mirror that performs near the optical diffraction limit"*. As can be seen from Figure 1 of our [Project Managers](#) article, this in fact is what REOSC has now achieved on our 8.1m blank. To get some sense of how smooth our mirror will be on its support system, if this mirror were stretched across the Atlantic Ocean, the largest wave would be no higher than a foot (30cm).

### Australia Joins Gemini!

By the time this Newsletter is printed, I anticipate Australia will have become a formal member of the Gemini Partnership. Over the last year, the original partnership has been through an extensive consultation process to decide how best to expand the partnership. In October 1997, the International Gemini Science Committee (GSC) resolved that; *"The GSC is unanimous that Australia should be accepted into the Gemini Partnership. Australian participation would strengthen the partnership by adding significant technical and astronomical expertise."* This was followed in November 1997 by the decision of the Gemini Board to ask the National Science Foundation to open negotiations with the Australian Research Council. The Gemini Board articulated a key principle in Australian participation, *"With existing partners now current on payments there is no financial crisis to be addressed. Therefore, the Australian contribution should be used to accelerate the on-going instrumentation program and enhance the scientific productivity of the telescopes."*

Welcome Australia!

*-Matt Mountain*

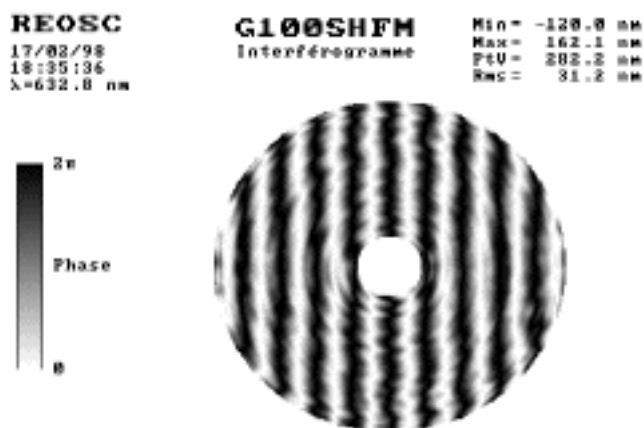


# Project Status

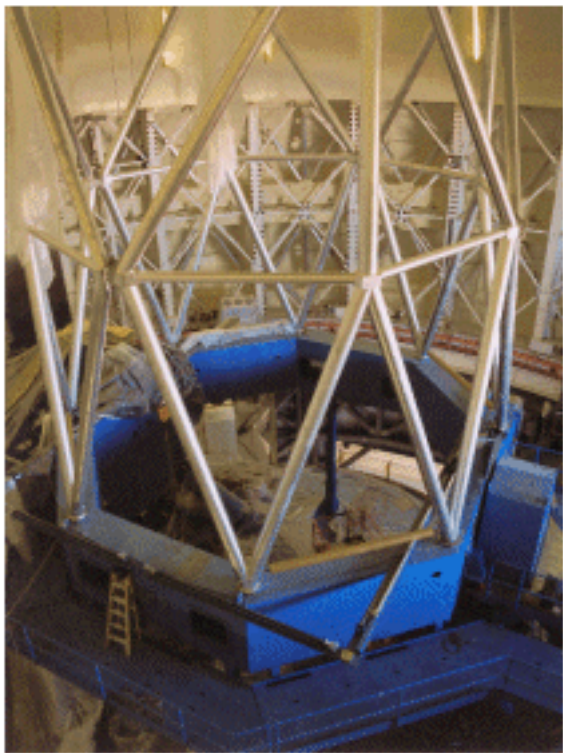
## Project Status Update - June 1998

The project has started the critical system integration efforts on Mauna Kea, projected to lead to first light in December 1998. The increase of operations personnel in Hawaii to support these activities has gone well. We now have more people in Hawaii than in Tucson, and are continuing the ramp up through a combination of relocating current employees and hiring new ones.

The first completed primary mirror, the best of its size to date, has arrived on the Big Island of Hawaii as shown on [the front cover](#). A sample of the acceptance measurement is shown in Figure 1. We are in the somewhat unique situation of having to store the mirror at sea level, since the facilities at the mountaintop are not quite ready. While several activities reported in the last newsletter have taken longer than anticipated to complete, we are still well along the way towards first light. A good example of this is shown in Figure 2, which shows the telescope structure almost completely erected within the enclosure on Mauna Kea. "First Oil" was declared in March when the telescope mount base, azimuth wrap, and hydrostatic bearing system were integrated and the telescope was first `floated` on an oil film. The several hundred tons of structure can now be pushed in azimuth by hand (one person!).



**Figure 1.** REOSC measuring results for Primary Mirror #1.



**Figure 2.** Installation of the northern telescope structure.

Through cooperation of our employees, partners and subcontractors, all the delays have been accommodated through a combination of working several activities in parallel and reworking of the order of events on Mauna Kea. The major activities, in addition to the telescope erection, include continued work on the enclosure; building fitout work; optics group work on primary mirror equipment; and the beginning of the system cables and services installation on the telescope. The Gemini North enclosure is now complete, and shown on the inside front cover.

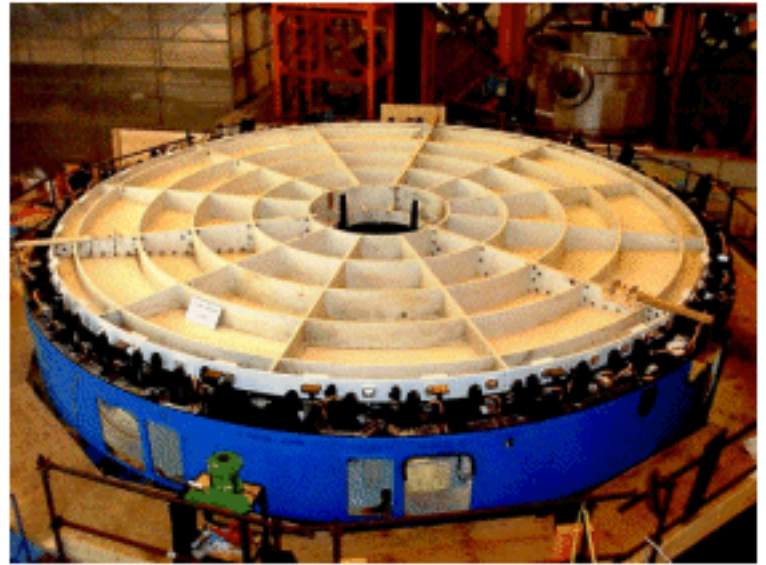
The Mauna Kea coating chamber has had its initial vacuum testing, which far surpassed our requirements by a large margin - producing a vacuum of better than  $5 \times 10^{-8}$  Torr. It will be ready to accept the primary

mirror this June. A steel dummy primary mirror and the primary mirror lifting fixture have been assembled on site, with work beginning on the cleaning base. The cabling work done to date includes the power runs onto the telescope and initial run of control cable from the telescope to the computer room where the communications and networking equipment has been installed. On the back cover, one can see a picture of our Hilo Base Facility nearing completion.

In Chile on Cerro Pachón, the enclosure erection work shown on [the inside back cover](#) is well underway with the arch girders and ventilation gate support system in place. We are working to reach weather tight status before the winter sets in, to allow the work inside to continue uninterrupted. The work to fitout the support building and interior has also now begun.

At REOSC, just outside of Paris, the second primary mirror is in the polishing stage, on or even slightly ahead of schedule (see [the inside front cover](#)).

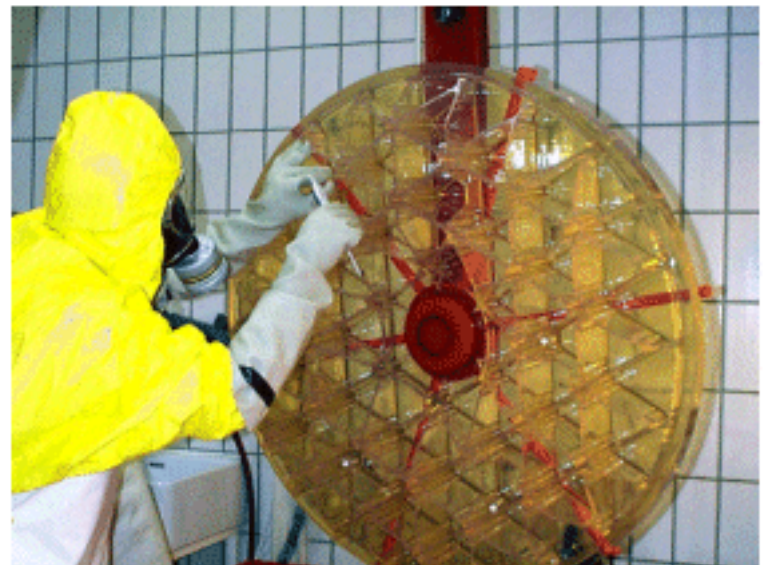
The first primary mirror cell assembly, with its support systems, has now been completed by the Gemini/RGO team in France at NFM. The system, tested with a steel dummy mirror, is shown in Figure 3. The system is now on its way to Hawaii, to arrive in late June.



**Figure 3.** The first primary mirror cell with steel dummy mirror in place.

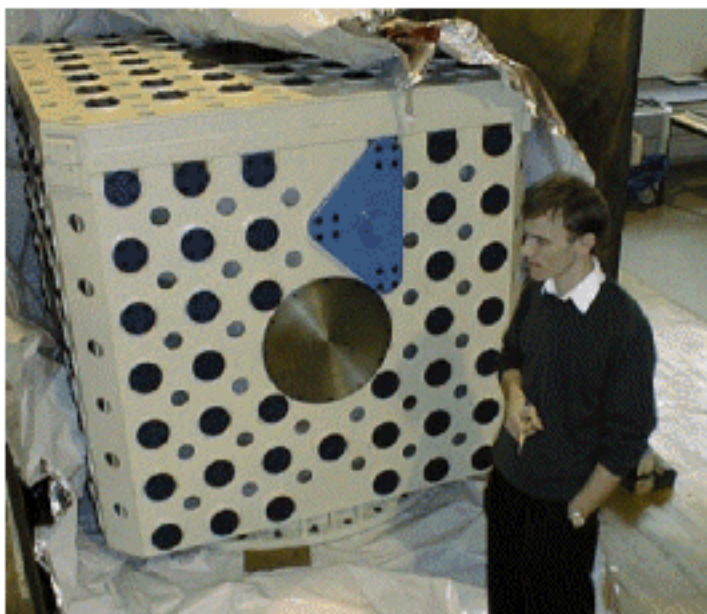
On secondary mirror systems, Morton Advanced Materials has not been able to produce a SiC (Silicon Carbide) blank. Zeiss, the primary contractor, is producing a light weight Zerodur mirror for first use during commissioning (see Figure 4). The Project is starting the procurement of a second glass mirror, while re-evaluating our longer-term requirements and schedule for high performance blanks. The first lightweighted mirror is on schedule for delivery this summer.

The first tilt system from Lockheed Martin has been accepted, shipped to Tucson, and is being integrated with the positioning and baffle system produced by Gemini and the secondary control system from ROE.



**Figure 4.** Secondary mirror at Zeiss.

In the area of facility instrumentation, the first Instrument Support Structure has been completed by AMOS in Belgium and sent to Zeiss for integration with the Acquisition and Guiding system, which is well into the final integration and test activities in Jena, Germany (Figure 5). The wavefront sensors and acquisition cameras from RGO and HIA will be first integrated with the Zeiss work in a May/June timeframe. The Cassegrain rotator is in fabrication, also at AMOS in Belgium. It is expected in Hawaii in the late summer. The prime focus wavefront sensor had a successful run on UKIRT, with excellent comparison to UKIRT's wavefront sensor. The Calibration Unit had its preliminary design review this past January and is proceeding well. Most facility instrumentation handling equipment has been fabricated, tested and delivered to Hawaii.



**Figure 5.** The Instrument Support Structure (left) and the Acquisition & Guiding Unit (right).

The ALTAIR system (Gemini North natural guide star adaptive optics (AO) system) is working towards its Critical Design Review next January. We have begun detailed planning for upgrading this system for use with a sodium laser guide star (LGS). On adaptive optics for Cerro Pachón, site characterization testing was started in January and will proceed throughout the year.



**Figure 6.** Progress on NIRI.

1999. NIRI parts can be seen in Figure 6.

The science instruments in fabrication include the Near Infrared Imager (NIRI), Near Infrared Spectrograph (NIRS), Gemini Multi-Object Spectrograph (GMOS), and the shared instrument with the UK, Michelle. Though NIRI will not be available for first light, the University of Hawaii has offered use of an existing near-IR instrument for first light and initial commissioning purposes. NIRI is scheduled for completion in March of

In the Software and Controls area, RGO and DRAL have completed the Telescope Control System (see the UK Project Office report). It is an impressive piece of software to which

we have begun to integrate other software systems. The Enclosure Control System, Data Handling System, and Secondary Control Systems have also been completed by HIA in Canada (ECS and DHS) and ROE in the UK (SCS). The project team has also made much progress on the Observatory Control System. Initial releases of key parts of this have received much praise from various members of the partner scientific communities.

The next six months will be extremely exciting and difficult for the Gemini project team and partners as we work toward first light on Mauna Kea at the end of this year. It won't be too long afterwards that we reach this point at Cerro Pachón! Updates about our progress can always be found on our web site, which is undergoing renovation to bring in more operational features. We look forward to this major milestone we have all been working towards for years. Wish us luck!

*-Jim Oschmann  
Gemini Project Manager*

## Hot News

### *From Australia*

Australian astronomers are looking forward to joining their colleagues in the International Gemini Project, as soon as the revised agreement is signed -- possibly by the time this newsletter appears. The Australian Research Council will bring an additional \$9.2M into the partnership, which will be used to accelerate instrument development for Gemini. Competition between the 8 meter telescope projects in second generation instruments is going to be very keen. Gemini needs this supplement, and we're happy to be coming aboard.

*-Jeremy Mould  
Australian Project Contact*

*Editor's Note: Australia has indeed joined the Partnership, signing the International Agreement on May 26th.*

# Operations

## *The Gemini Observatory Science Operations Plan*

This article introduces several aspects of the Gemini Science Operations Plan. (For a more complete description see [\[1\]](#)). One of the key challenges, which impacts science operations in many areas, is to ensure that the telescopes can exploit exquisite site conditions when they occur whilst recognizing that the telescopes must be used effectively and efficiently a much larger fraction of the time.

### **Telescope Proposals**

The main feature that distinguishes the Gemini proposal process from conventional ground-based telescopes is that it comprises two stages. The intent is not to subject unsuccessful applicants to the, necessarily time-consuming, detailed observation planning stage. Phase I applications, solicited twice yearly, will be made to the responsible body (National Time Allocation Committee, NTAC, or National Gemini Office, NGO) within each of the Gemini partners. These applications will be evaluated to establish their scientific merit as well as their technical feasibility. To serve this purpose, Phase I proposals must therefore contain a scientific justification, technical description of the instrument resources and time justification, proposer information, target details, scheduling constraints and availability of guide stars.

For queue programs the scheduling constraints define the poorest site conditions (e.g. image quality, cloud cover, IR or optical sky brightness) under which each observation can be carried out as well as any time constraints. In general the constraint details are still to be defined but will likely be based on the frequency of occurrence. Thus the image quality might be specified in one of four bins (best 20%-ile, 50%-ile, 90%-ile and unconstrained; the latter accounting for an extended tail in seeing distributions) with the actual encircled energy or Strehl ratio corresponding to these percentiles defined separately for several principal wavelengths.

Demonstration of the availability of guide stars, though not necessarily identification of the specific stars to be used, is an important aspect of the Phase 1 information, and its technical justification, because of the key role of peripheral and on-instrument wavefront sensors (WFSs) in delivering the image quality and guiding performance. The principal object catalogue for guide star selection will be the "second generation" Guide Star Catalogue (GSCII) presently under construction at STScI, with the 2-MASS point-source catalogue also of value, particularly in dark clouds.

Each NTAC (or NGO) will electronically transmit to Gemini two ranked lists of proposals it would like to see scheduled in order of scientific priority, one for classical programs and one for queue, together with the recommended time allocation. It is expected that the combination of the list and

recommended times will substantially exceed the expected allocation, to allow some degree of flexibility in merging the national lists. From simulations of the queue execution process [2] it is anticipated that this overloading will be in the range 25-40%, although this value is subject to variations in site conditions about which we have presently only sparse information.

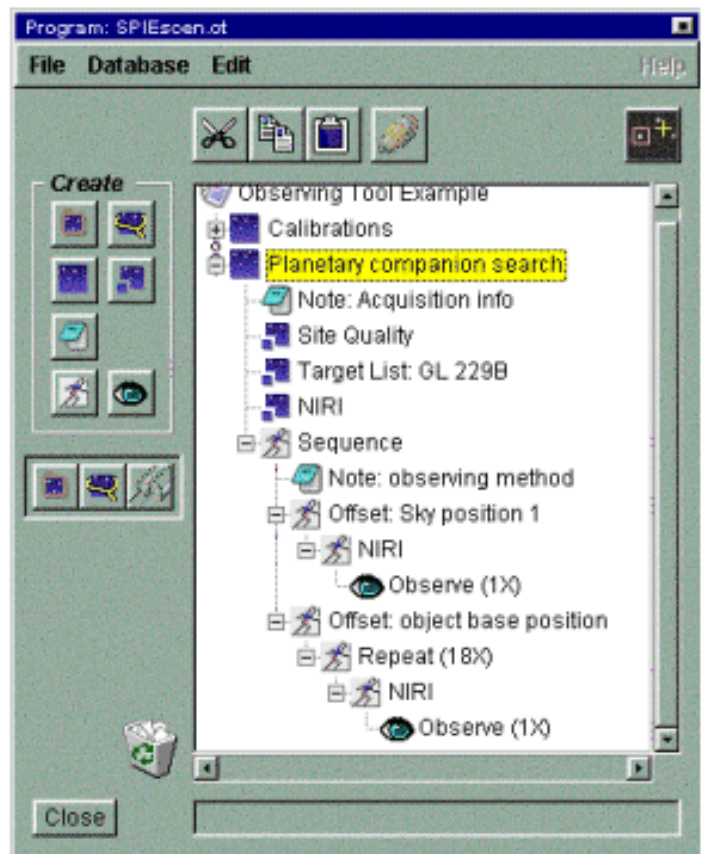
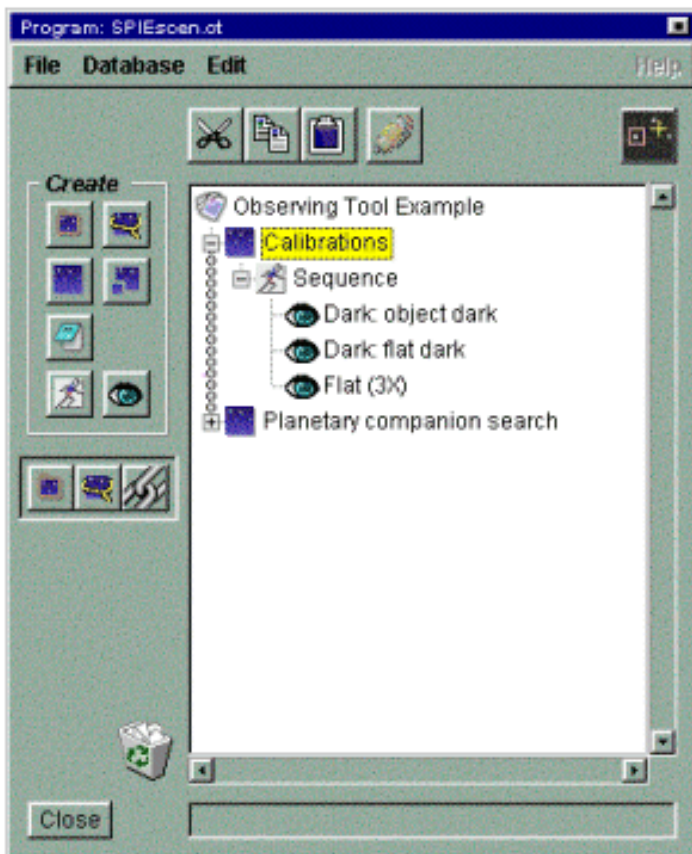
The International Time Allocation Committee (ITAC) consists of representatives from Gemini and the NTACs, and is advisory to the Gemini director. It meets to consider modifications to the draft schedule and draft queue required by conflicts identified in the merging process and subsequent execution simulation. If necessary, programs may be moved from one observing mode to the other, or additional programs may be substituted from the NTAC lists, based on the best scientific judgment of the ITAC. The final recommended schedule and queue are forwarded to the Gemini director for approval.

## **The Observing Tool**

Each successful proposal will be assigned a contact scientist (CS) who is the Gemini representative for that program. For queue programs the CS is responsible for ensuring that all information required to execute the program is available to the observer. This information is submitted in Phase 2 of the application process. Phase 2 proposals are developed using the Observing Tool (OT) JAVA software distributed to all proposers. The OT allows the queue investigator to work directly with the Phase 2 database at the Gemini sites, or off-line, via a graphical user interface to define completely their observations, select and sequence instrument, telescope and data processing configurations, refine Phase 1 positions, describe acquisition requirements and constrain observation scheduling by grouping, chaining or specifying temporal controls.

The OT is no less important for classical observers, as well as the Gemini queue observing staff, as it provides the instrument user interface and the means for constructing simple or complex sequences of observations at the telescope. Some of the features of the OT, and the deep level of integration between the observatory and telescope control systems and the data handling system, are best illustrated via a science scenario.

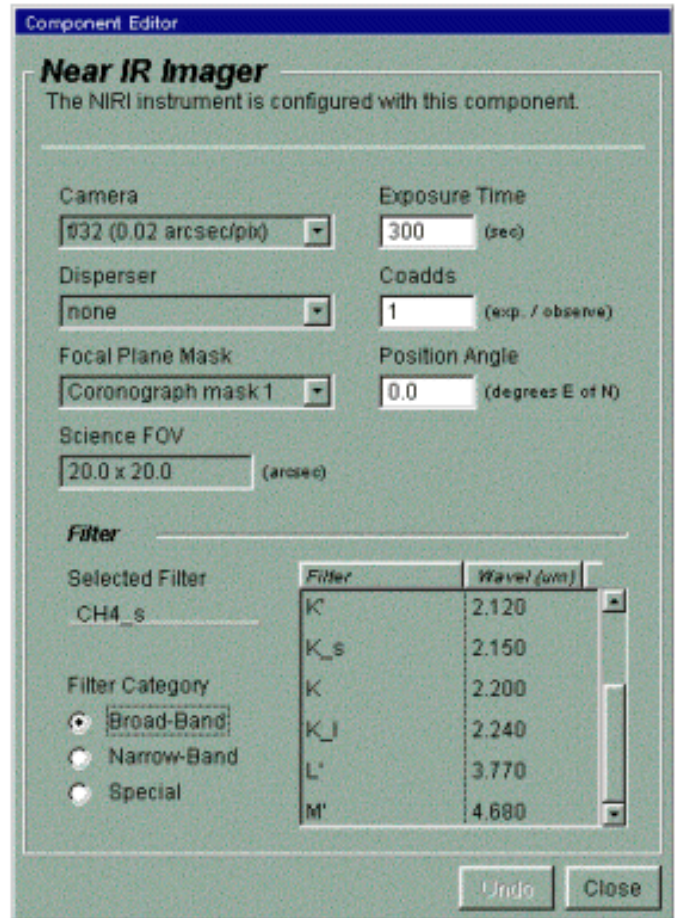
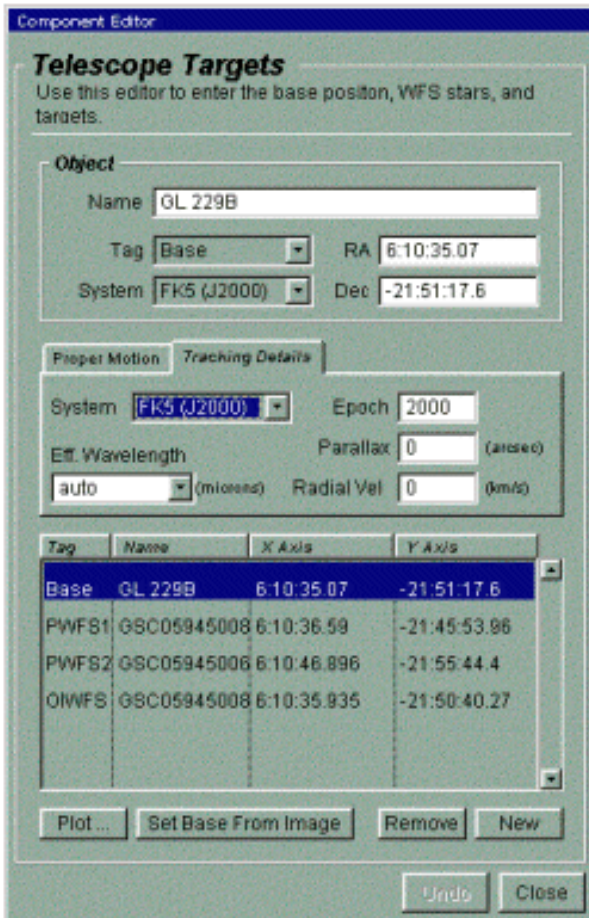




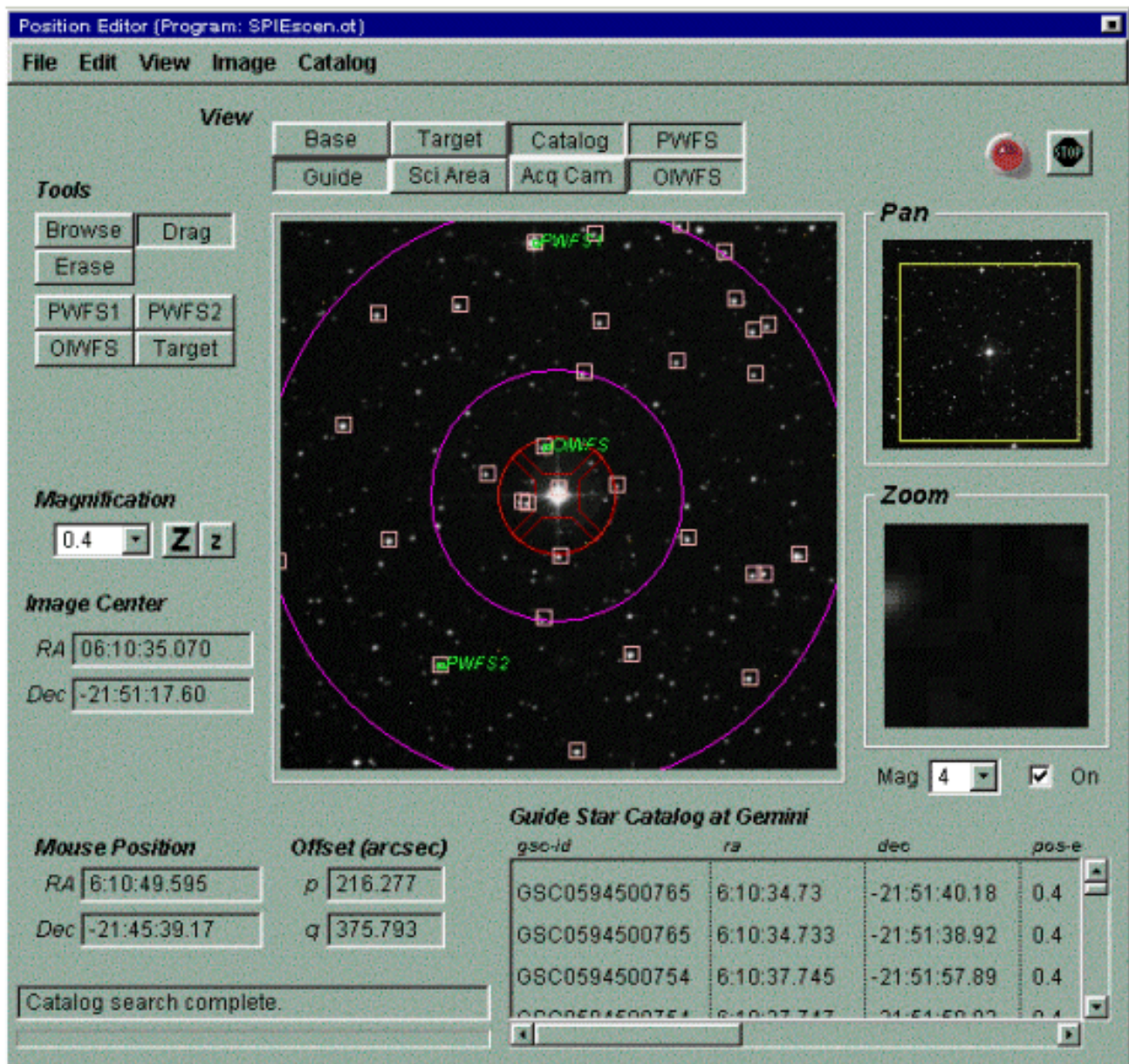
**Figure 7.** The program development screen from the Observing Tool showing (a) the calibration observation and (b) an expanded view of the science observation.

Let us suppose we wish to observe the nearby M-type star GL229B to search for sub-stellar companions. The observations will make use of the near-infrared imager and employ a differential technique observing alternately in two narrow-band filters in and out of the deep methane absorption near  $1.6\mu\text{m}$  expected in the low-mass companion's spectrum. GL229A will be placed behind a cold coronagraphic occulting mask to reduce scattered light from the primary. Minimizing systematic effects is important in such observations and thus we have elected to intimately associate the calibration observations (detector dark current and flat field) with the science observation. Within the OT one such grouping method is to "chain" the observations (note the chain links in Figure 7a) which enforces their consecutive execution. The GL229B observation description from the OT is shown in an expanded hierarchy in Figure 7b.

Each major aspect of the observation is defined by its own component. For example, the "target list" component (Figure 8a) specifies the base pointing position as well as the pre-selected guide stars to be used by the peripheral and on-instrument wavefront sensors, and the "NIRI" component (Figure 8b) defines the initial instrument configuration. The target list may be viewed graphically (Figure 9) using a representation of the telescope field with overlays of the wavefront sensor positions and sensor constraints, possible (catalogued) guide stars, telescope sequence positions and science field. The image of the field may be drawn from sky survey images, images from other telescopes, or images from the Gemini acquisition camera or science instruments.



**Figure 8.** The Observing Tool components used to define (a) the telescope and wavefront sensor positions and (b) the near-infrared imager configuration.



**Figure 9.** Visual representation showing catalogued guide stars (square boxes), those selected for the wavefront sensors (labelled) and patrol fields for the WFSs: outer circles for the peripherals and inner circle and vignetting pattern for the on-instrument.

Selection of this observation for execution causes several parallel actions. The telescope slews to the target, the peripheral and on-instrument wavefront sensors position themselves in the expected locations to receive light from the guide stars and the instrument camera and filter mechanisms adopt the desired configuration. Often, and particularly in this instance, the observing team would have configured the control system to pause before the observing sequence itself is started to allow fine adjustment of the telescope position for target acquisition.

In this case the observing sequence is rather simple involving numerous repetitions of successive exposures through the two filters. However the OT also allows complex sequences to be built up by iteration over any of the instrument mechanisms and co-ordination with telescope motion. Likewise the on-line data processing system can be pre-configured by the OT to reflect the data-taking

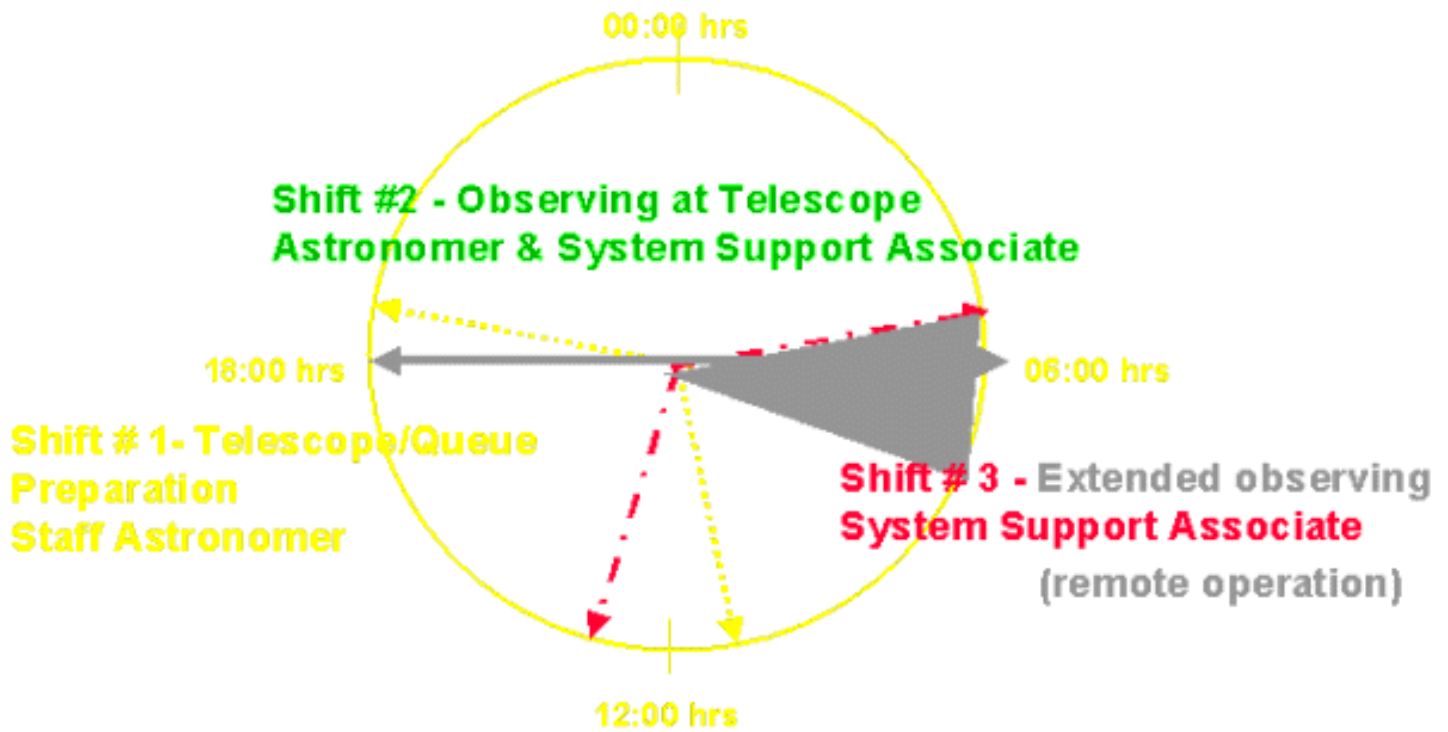
sequence by attaching recipes driving IRAF (or IDL) scripts at any of the nodes in the observation hierarchy. Examples might be for dark current subtraction and flat-fielding after each exposure ("Observe" node in Figure 7b), differencing of the two filter images ("NIRI iterator" node) and combination of accumulated data ("Repeat" node). Each of the intermediate or final data processing products may be displayed in a variety of formats on a quick-look display. The intent of this system is to provide real-time quality assessment to the observers so that they may adjust details of the observation.

A "library" of commonly executed observation and data processing configurations and sequences is provided as part of the OT which may be cut-and-pasted to accelerate program definition.

## **Scientific Support**

Scientific support for users of the Gemini telescopes will be provided by a combination of Gemini staff and the National Gemini Offices (NGOs). Broadly, Gemini will be responsible for observation execution, on-site support, providing expert response to user queries and as the control authority for the release of general information and data. The NGOs will be responsible for pre- and post-observation support and will be the first point of contact for user queries. It is not expected that each NGO will maintain a full complement of staff capable of responding to queries in all areas, instead a distributed support network, involving collaborative support amongst the partners, is envisaged. We are presently exploring commercial help desk and knowledge base solutions to managing this distributed support activity. It is anticipated that the Gemini scientific staff will be further augmented by extended visits from astronomers in the Gemini community who can contribute their wide experience and expertise to the operation of the facility and help foster a lively scientific culture.

The planned Gemini science support staff totals about 33 FTE and includes an associate director at each site, as well as an associate director for instrument and facility development, fixed-term science fellows (5-6 at each site), long-term staff astronomers (3-4 at each site) and system support associates (6 at each site). Several aspects of the interaction between the staff during routine operations can be seen in Figure 10 that illustrates the daily cycle of operations.



**Figure 10.** The daily cycle of telescope operations and scientific staffing requirements.

There are three shifts, effectively providing continuous staffing:

- Shift #1 runs from 11am until 7pm and is executed by a Gemini staff scientist from the sea-level operations room. In this shift scheduling tools and weather predictions are used to draw up plans for the nighttime observations, calibrations and instrument checks are performed using the facility calibration unit when permitted by engineering and maintenance activities, and the telescope and enclosure are conditioned. The latter involves establishing equilibrium between the dome air, telescope structure and mirror temperatures with the expected air temperature, as well as setting the mirrors' rate of change ( $dT/dt$ ), for the start of nighttime observing. To meet the stringent image quality requirements, the mirror surface must be maintained within  $\frac{1}{2}^{\circ}\text{C}$  of the ambient temperature. Depending on the accuracy of the weather forecast, the shift operator may use the scheduler with a number of different sets of conditions and "policies" (describing the combination of parameters affecting queue execution) to construct several nighttime plans using the Observing Tool to link together pre-defined observations from a number of different programs.
- Handover to shift #2 occurs at 6pm, commencing with the arrival of the nighttime observing team, Systems Support Associate and staff or visiting observers, at the summit. This provides an overlap of one hour for shift #1 to update the second team on the system status, calibrations and to discuss the observing plan. However, the queue observer has the minute-by-minute responsibility for the decision of what observation to execute and, after evaluation of the current environmental conditions or if an instrument is malfunctioning for example, may choose to switch programs in a way not reflected by the possible plans. The queue observer is also responsible for understanding the programs in sufficient depth to know how to make the

observations and how to evaluate the success of the observations. Medium range schedules, typically drawn up 7-14 days in advance from models of the queue execution, will enable the contact scientists to discuss likely upcoming programs with the queue observers.

- Shift #3 runs from 5am until 1pm and is carried out by a SSA at the sea-level facility. The one-hour overlap before the nighttime shift relinquishes control of the telescope at 6am allows for an update of that night's observations and communication of any faults or problems that might have occurred. It is anticipated that development of a near-infrared peripheral wavefront sensor will enable science observations in the thermal infrared to continue for several hours after morning twilight, to be controlled from sea-level and with safe telescope shut down verified by the daytime summit engineering team. The shift #3 operator will also be responsible for archiving the data and for arranging its distribution and quality assessment by the contact scientist.

## Acknowledgements

The Gemini Science Operations Working Group has contributed greatly to the development of the Gemini science operations plan.

## References

- [1] Puxley, Gillett, Mountain and Simons 1998. SPIE 3349. ([Gemini preprint #26](#)).
- [2] Puxley, P.J., 1997. SPIE, 3112, 234. ([Gemini preprint #19](#)).

*-Phil Puxley  
Associate Project Scientist for Operations*

# Gemini Preprint #26

---

## The Gemini Observatory Science Operations Plan

Phil Puxley, Fred Gillett, Matt Mountain, Doug Simons  
*Gemini 8m Telescopes Project, 950 N. Cherry Ave., Tucson AZ 85719*

### **Abstract.**

We review the Gemini Observatory science operations plan including the proposal submission, allocation and observation planning processes; the telescope operations model; and the scientific staffing plans and user support. Use of the telescope is shown by via a scenario involving a sub-stellar companion search program to illustrate the planning tools and level of integration required between the observatory control, telescope control and data handling software systems.

Appears in Proc. SPIE 3349, "Observatory Operations to Optimize Scientific Return".

Download the [PostScript](#) or [PDF](#) file.

---

Ruth A. Kneale / [web@gemini.edu](mailto:web@gemini.edu) / March 30, 1998

# Gemini Preprint #19

---

## Execution of Queue-scheduled Observations with the Gemini 8m Telescopes

Phil Puxley

*Gemini 8m Telescopes Project, 950 N. Cherry Ave., Tucson AZ 85719*

### **Abstract.**

Queue scheduling will be one of the major modes of operation of the Gemini 8m telescopes in which scientific programs will be carried out on behalf of applicants by Gemini staff. Use of a substantial fraction of the available telescope time in this manner will permit access to the exquisite conditions of image quality and background which the telescopes are designed to exploit as well as matching the demands of individual observations to the current conditions. In a previous presentation (SPIE 2871) the classical scheduling and loading of the queue were described. In this paper we discuss the philosophy and parameters which define its execution. Results from detailed simulations of the queue execution process are presented.

Appears in Proc. SPIE 3112, "Telescope Control Systems".

Download the [PostScript](#) or [PDF](#) file.

---

Ruth A. Kneale / [web@gemini.edu](mailto:web@gemini.edu) / August 26, 1997



# Feature Article

## *Gemini WFS CCDs and Controllers*

### Introduction

Each Gemini telescope will use four types of wavefront sensors (WFS). Two peripheral WFSs (PWFS) are located in the Instrument Support Structure (ISS). These low and medium order (2 x 2 and 6 x 6 subapertures) WFSs are the primary source of information on atmospheric turbulence and windshake. Tip/tilt and focus errors measured by the PWFSs are used by the secondary mirror control system to correct the incoming wavefront.

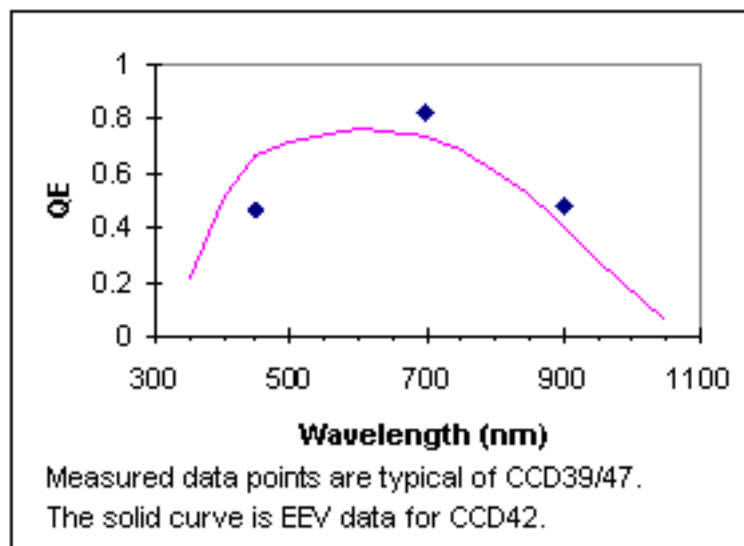
The High Resolution WFS (HRWFS) is also located in the ISS. This high order (20 x 20 subapertures) WFS is used to update the primary mirror figure correction. By removing the lenslets from the optical path, the HRWFS can also be used as an Acquisition Camera (AC).

On-Instrument WFSs (OIWFS) are located on Gemini instruments. Their primary purpose is to correct for flexure and therefore are low order (2 x 2 subapertures). OIWFSs may also be used to correct atmospheric turbulence, since they can patrol closer to the science object than the PWFSs.

The Gemini Adaptive Optics System includes an AO wavefront sensor (AOWFS). This high order (12 x 12 subapertures) WFS is used in conjunction with a deformable mirror and a tip/tilt mirror to provide high Strehl ratio images to other Gemini instruments.

### 1. Sensors

A sensitive wavefront sensor requires a high quantum efficiency (QE) detector with low readout noise. To achieve high frame rates, a frame transfer device with a format matched to the size and number of subapertures is needed. An 80x80 split frame-transfer device from EEV (CCD39) was selected for the PWFSs, the OIWFSs and the FWFS. A larger 1024x1024 frame transfer device from EEV (CCD47) was selected for the HRWFS/AC. To achieve a high QE, both devices are thinned (backside-illuminated), and anti-reflection coated (red enhanced). Figure 11 shows the typical QE as a function of wavelength.



**Figure 11.** CCD39/47 Quantum Efficiency.

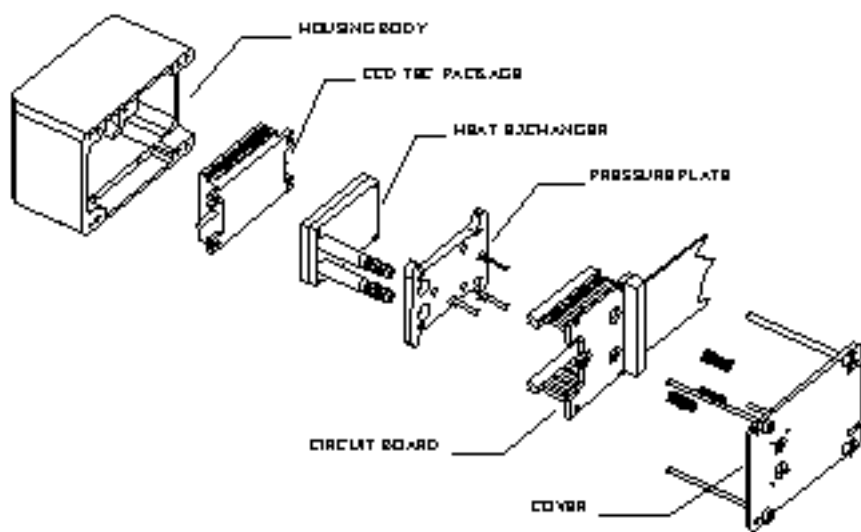
The four ports on CCD39 allow it to be readout in 3.1 ms (at 1.6 $\mu$ s/pixel). The larger CCD47 with only two ports requires 620 ms for a full frame readout (at 1 $\mu$ s/pixel). Table 1 gives the read noise as a function of pixel readout time. CCD47 figures are for engineering grade devices. Full spec. CCD47s are not expected until the 3Q98.

<b>Table 1: CCD39/47 Read Noise</b>		
<b>Pixel Readout Time (<math>\mu</math>s)</b>	<b>CCD39 Noise (electrons rms)</b>	<b>CCD47 Noise (electrons rms)</b>
1.0	8.1	--
1.6	5.3	--
2.6	4.5	6.9
10.6	3.9	5.9

In order to take advantage of the low read noise, the dark current must be reduced to the point where the dark noise is insignificant compared to the read noise. Under certain circumstances this can be achieved by using inverted mode operation (IMO)<sup>1</sup>. In other cases, a small amount of cooling, compatible with the use of thermoelectric coolers (TECs), is required. For example, an EEV advanced IMO CCD operating at a 200 Hz frame rate (0.5 ms integration time) will have a dark signal of only 1 electron/pixel at a temperature of about 10°C. If one were to imagine the guide star photons spread over 36 pixels in each of four subapertures, then a 12th magnitude star would give an average 5:1

signal to noise ratio (SNR)<sup>2</sup>. If you want to use a fainter guide star, say 18<sup>th</sup> magnitude, then you need to increase the integration time to about 1 second and reduce the temperature to about -30°C to get the same dark noise and SNR. Alternatively, you could leave the temperature at 10°C and increase the exposure time to 4 seconds to achieve the same SNR. In this case, the dark current (~36k e) would use up a significant portion of the dynamic range of the detector (full well = 100k to 200k e).

EEV offers a package option in which the CCD and a thermoelectric cooler are sealed inside a metal and ceramic case with a quartz window. The TEC package is evacuated and then backfilled with Krypton. This process provides adequate thermal insulation without the problems associated with maintaining a high vacuum. The maximum differential temperature between the hot-side (package) and the cold-side (CCD) is about 48°C. This corresponds to a cooler current of 2.5 A and requires the removal of about 6 watts of heat from the back surface of the package. At higher currents the cold-side temperature begins to rise.



**Figure 12.** WFS CCD housing.

A simplified assembly drawing of the WFS CCD housing is shown in Figure 12. This compact unit is 58mm wide, 85mm long and 50mm deep. The CCD TEC package is located in the housing body using the mounting lugs that extend from the ends of the package. A 60/40 water/glycol mixture at ambient temperature (-10 to +15°C) is pumped through the heat exchanger. At maximum cooling and a flow rate of 0.5 liters/min.,

the CCD package is about 2°C warmer than the coolant. Thus the lowest temperature the CCD can be operated at is -56°C to -31°C, depending on the ambient temperature. The pressure plate and springs hold the heat exchanger against the back of the CCD package.

The printed circuit board routes the bias, clock and video signals from the CCD pins to the cable connector. Electrical connections to the head are made via a single fine-pitch ribbon cable. The outer six conductors (30 AWG, stranded) on either side of this cable are used to

supply the TEC current. No preamplification of the video signal at the WFS head is employed but the system achieves adequate noise performance for cables up to 1m in length. Each video conductor is bracketed by a pair of ground conductors in the ribbon cable. No shielding was found to be necessary in the laboratory environment. If shielding is required on the telescope, then a flexible woven shielding tape will be applied to the ribbon cable.

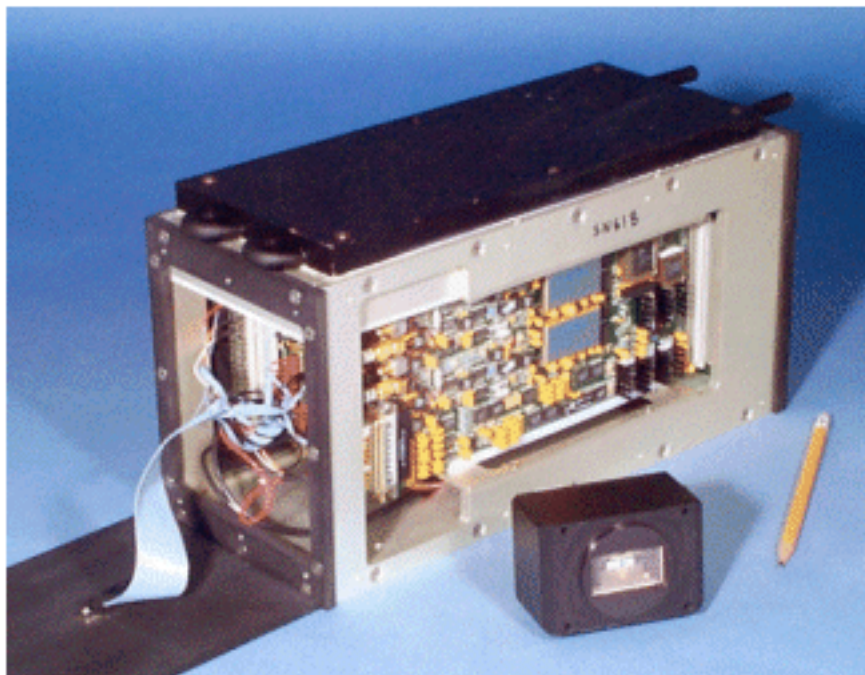
## 2. Controller

A single type of CCD controller that would operate each of the different WFSs was desired. It therefore had to meet the following criteria:

- readout two and four port devices
- operate at up to 1.4 Mpx/s on each port (set by FWFS @ 1000 frames/s)
- not contribute significantly to the read noise of the sensor
- permit exposure times of 1ms to 100s of seconds
- be capable of interfacing to a VME host (Gemini standard I/O controller)
- be capable of controlling a TEC
- not dissipate significant heat to the instrument environment

A controller manufactured by Dr. Bob Leach at the San Diego State University was found to fulfil most of the requirements. This controller, the SDSU2, is a second generation system based on a popular earlier model. It can be configured for 1 to 16 input channels, each capable of up to 1 megapixel per second (Mpx/s). The throughput of the controller is 2.7 Mpx/s so the channel rate in a 4 port system is limited to about 670 kpx/s (a limitation for the FWFS).

A modification to the standard enclosure was required to meet the last criteria (see Figure 13). A liquid heat exchanger bolted to the top of the aluminum enclosure is used to keep it at, or near, the ambient temperature. A fan circulates air through a set of heatsink fins and past the circuit cards. With a coolant flow rate of 2 liters/min., the difference between the coolant temperature and the enclosure temperature is less than 5°C and the difference between the coolant temperature and the air temperature inside the enclosure is less than 15°C.

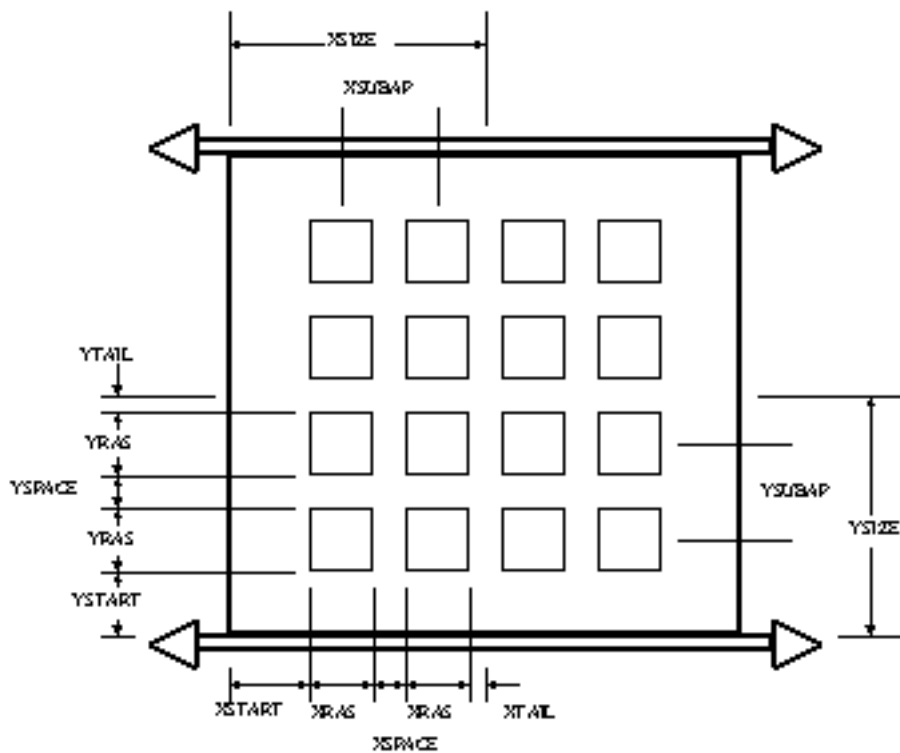


**Figure 13.** WFS Controller and CCD Housing.

### **3. Readout Software**

The SDSU CCD controllers are supplied with DSP software to perform full frame readout. The code defines a basic command/response communications protocol between the system elements (host, host interface DSP, timing DSP and utility DSP). The command set and the readout code have been modified, as described in the following sections, to adapt them to the requirements of a system of WFSs.

#### **Generalized Readout Geometry**



**Figure 14.** Generalized Readout Geometry

In order to minimize the readout time, only those portions of the CCD that correspond to regions of interest within the subapertures are read out. The remaining pixels are discarded. A generalized readout geometry that can be applied to any of the WFSs has been adopted. Figure 14 is an example of an array of 4x4 digitized subapertures (2x2 per quadrant). The number of subapertures, their size and their position in a rectangular grid, are set by run-time parameters. These are downloaded from the host to reserved memory locations on the timing board. The parameters

XSUBAP and YSUBAP define the number of subapertures to be readout. XRAS and YRAS give the size of the subapertures in binned pixels. The parameters XSPACE and YSPACE set the number of columns and rows to be discarded between subapertures and XSTART and YSTART give the number of columns and rows that are discarded before the first subaperture. To minimize the readout time, discarded rows are binned together before the charge is flushed from the serial register. With CCD47 this latter operation can be accomplished by pulsing the dump gate. In CCD39, the complete row must be transferred to the output. Table 2 indicates the minimum readout times that can be achieved for three of the WFS configurations. The data link is the limiting factor in 4-port systems, whereas, the ADC conversion time limits the speed of 2-port systems.

<b>Table 2: Minimum Readout Times</b>			
<b>WFS</b>	<b>Subapertures</b>	<b>Pixels/subap</b>	<b>Measured Min. Readout Time (ms)</b>
PWFS & OIWFS	2x2	6x6	0.4
PWFS	6x6	6x6	1.24
HRWFS	20x20	6x6	66.5
AOWFS	12x12	2x2	0.9*

* requires special coding
---------------------------

## Frame Synchronization

Synchronizing the frames from multiple WFSs, in an interleaved fashion, reduces bus contention in the host computer. It also has the side benefit of more uniformly sampling the wavefront. Since the crystal clocks in the various WFS controllers can vary in frequency by a few parts per million, over the long term (many thousands of exposures), initially synchronized WFSs will drift apart. Exposure synchronization must therefore come from the host computer. Initiating each exposure for each WFS would overload the I/O capabilities of the host processor. Instead, the host processor requests a number of exposures from each WFS corresponding to a time interval over which the WFSs should remain roughly synchronized. When, based on its internal clocks, the host computer expects that the first series of exposures has completed, it requests a new series of exposures and so on.

If a readout command is received by the WFS controller during the timing of the last exposure of a sequence, the controller is "slow" compared to the host timing. The current exposure should therefore be cut short before continuing with the next sequence of frames. If a readout command is received after reading out the final exposure in a sequence of frames, then the WFS controller is "fast". The timing board should begin timing a new sequence of exposures, introducing a gap in the exposure sequence. Unfortunately, the timing board can only check for commands during exposure timing or when idle. It is occupied with time critical control sequencing during the frame transfer and readout operations. If a readout command is received while these operations are in progress, then the command will not be acted upon until the current sequence of exposures completes. In other words, the WFS controller will be treated as though it were "fast" when in fact it is "slow". Subsequent readout commands will occur sooner in the process of the last exposure until they occur in the exposure timing portion and the controller is recognized as being "slow". The WFSs remain synchronized with the host computer with a jitter equal to the sum of the frame transfer and readout times.

## On-the-fly Parameter Changes

Once the WFSs have "locked onto" a guide star, the images in each subaperture will sharpen and remain close to the center of the regions of interest (ROI). It is therefore possible to reduce the size of each of the ROIs thereby reducing the readout time.

Alternatively, the binning factor could be reduced, increasing the resolution of the guide star profile. To accomplish this without interrupting the sequence of exposures, a scheme to change parameters on-the-fly has been developed. The difficulty with on-the-fly parameter changes is that if the WFS is operating at its maximum frame rate (i.e. the exposure time is approximately equal to the readout time) then there is little opportunity for the timing DSP to accept the new parameters. Fortunately, the timing board has a first-in-first-out (FIFO) buffer capable of storing about 80 parameter changes. If during each exposure, the timing board is permitted to accept one command at each check of the exposure timer, then, at most, the exposure time jitter will be the time required to decode the command and change a parameter (less than  $1\mu$  s). At worst, changing a given number of parameters may take an equal number of exposures. Once all the new parameters have been delivered to the controller, a "load parameters" command copies them from a temporary storage area to the parameter table used by the readout program. One of the changed parameters is a "parameter identifier (ID)". This piece of information is sent in the header of each frame of data that is delivered to the host. The changed parameter ID indicates to the host when the new parameter set is being used.

## 4. References

1. M.V. Zombeck, *Handbook of Space Astronomy and Astrophysics*, Cambridge Univ. Press, 1982, p.58
2. R. Leach and F. Beale, *Optical and Infrared Camera Electronics Users Manual*
3. EEV Technical Notes on CCD39, CCD47 and CCD42.

*-Brian Leckie and Tim Hardy  
NRCC/HIA, Dominion Astrophysical Observatory*

### Footnotes

1. IMO reduces the surface dark current by creating an inversion layer that drains charge to the channel stops.
2. Based on R-band energy (see Reference 1) and 50% transmission through the atmosphere and optics.



# **National Project Office Reports**

## **US Gemini Project Office**

**S**ubstantial progress has been made during the last six months on all the instruments and subsystems that are U.S. efforts:

The Institute for Astronomy at the University of Hawaii is fabricating assemblies for the Gemini Near-IR Imager (NIRI) as well as sending out non-critical parts to commercial machine shops. Almost all optical components have been delivered, though a few did not meet the specifications and need to be reworked. A critical component, the gimbal mirror steering mechanism for the On-Instrument Wavefront Sensor, recently passed a cold test, so it appears that full integration with Gemini control systems will be possible during instrument commissioning, which is scheduled for Spring, 1999.

NOAO held an interim review of the Gemini Near-IR Spectrograph April 30 to close out items not covered at the November 1997 CDR. The design is essentially complete, and optical procurement drawings are being released to vendors for quotes. Durham University in the UK is designing an Integral Field Unit for integration when the instrument is assembled next year.

A contract has been signed with the University of Florida to supply the Gemini Mid-IR Imager. Dr. Charles Telesco is the PI on this 8-26 $\mu$ m instrument. USGP personnel met with the team to tour their facility and to kick off the project. Delivery is scheduled for March 2001.

Santa Barbara Research Center has delivered six IR arrays, with two of them appearing to be of science quality in preliminary cold tests. Four more hybridizations are in process, and the remaining two attempts will be deferred until next year to take advantage of technology improvements.

The NIRI array controller is undergoing final system tests by Mike Merrill, Instrument Scientist and Andy Peters, the electrical engineer responsible for the controllers at NOAO. Preliminary results indicate that noise specifications will be met. The unit is expected to be delivered to the University of Hawaii this summer.

NOAO expects EEV to deliver the science grade CCD arrays this summer. As an aid to checking out the SDSU-2 controllers, Gemini will purchase three engineering grade arrays from EEV. Software development is on schedule. The first GMOS camera with fully integrated detectors and controllers is expected to be delivered to Canada this Fall.

USGP personnel have been directly and indirectly involved in the queue-scheduled operation of the WIYN Telescope on Kitt Peak since the inception of operations on this telescope. As Gemini will be

queue-scheduled for a significant fraction of the time, we believe this experience can supply valuable information both to the Gemini operations team and to the national Gemini offices. Now that the WIYN queue has been in operation for two years, its success can be evaluated by quantitative comparison with the predicted outcome of classically scheduling the same proposals on the same nights.

A comparison of queue and classical scheduling shows that the queue delivers improvements very similar to the predictions of simulations done before the queue was implemented. The overall efficiency of the telescope has been about 15% higher than it would have been were it classically scheduled. Roughly 4 times as many observations requiring sub-arcsecond seeing were obtained by the queue as would have been obtained otherwise. Approximately 2.5 times as many programs were completed as in the classical comparison.

Given the apparent success of the queue in enabling more observations, particularly those requiring rare conditions, it is interesting to note that the preference of the community would be to observe classically. A questionnaire circulated to every astronomer who has applied for time on WIYN probed the community's perception of the value of queue scheduling. The queue approach tends to polarize users' views: those who received data were pleased with its quality and with the experience, while those who were in the queue but did not receive data would rather have come to the telescope and taken their chances. By stressing the completion of programs, the queue results in a smaller number of users who get any data, and so the questionnaire responses seem to indicate overall dissatisfaction. It will be important for Gemini and the national Gemini offices to understand how to address this sort of reaction, which is likely to be aimed at queue-scheduled time on the Gemini telescopes.

*- Todd Boroson, Mark Trueblood*

# **National Project Office Reports**

## **UK Gemini Project Office**

### **The Telescope Control System Passes Final Acceptance**

**T**he Gemini Telescope Control system was begun in January 95. When we were preparing our project plans at that time we gave February 5th 1998 as the completion date. Now, three years later we are pleased to be able to say that we were almost spot on - the TCS passed its final acceptance testing and was handed over to IGPO on February 24th. We should add that we also contrived to complete within budget although at the time of writing we are still awaiting the final accounts.

The main purpose of the TCS is to enable the observer to form the best possible image of a specified target at a selected point in the focal plane. Since the TCS itself does not control any hardware directly (except for the time bus and an interface to the interlock system) it does this by co-ordinating the activities of each of the telescope control subsystems. On receipt of a command from the observer a series of commands are fanned out to the subsystems and when each of them reports it has completed its action the TCS signals back to the observer that it is ready to proceed.

The model adopted to develop the TCS was one of incremental delivery. A first prototype was presented at the System Design Review in August 95 that allowed the inputs of target positions and the generation of demands to the mount and rotator. This proved the basic design of how the pointing flow would be incorporated into the EPICS infrastructure. Each delivery since then has added increasing sophistication to the TCS. It is now possible to specify targets in a range of frames, simultaneously control up to three guide probes, offset both on the sky and in the focal plane, chop, nod etc. etc.

As the TCS was extended it was necessary to develop increasingly realistic simulators for each of the TCS subsystems in order to test and debug our code. A consequence of this is that it is possible to run the TCS completely standalone and yet provide very realistic responses to peer systems like the OCS. One very useful debugging tool has turned out to be a simulated TV display (complete with artificial stars) that allows you to see what will happen as the telescope is slewed and offset. Watching this whilst chopping, nodding and slewing the rotator is very instructive, as is tracking through the zenith!

*- The TCS Development Team  
Rutherford Appleton Lab. & Royal Greenwich Observatory*

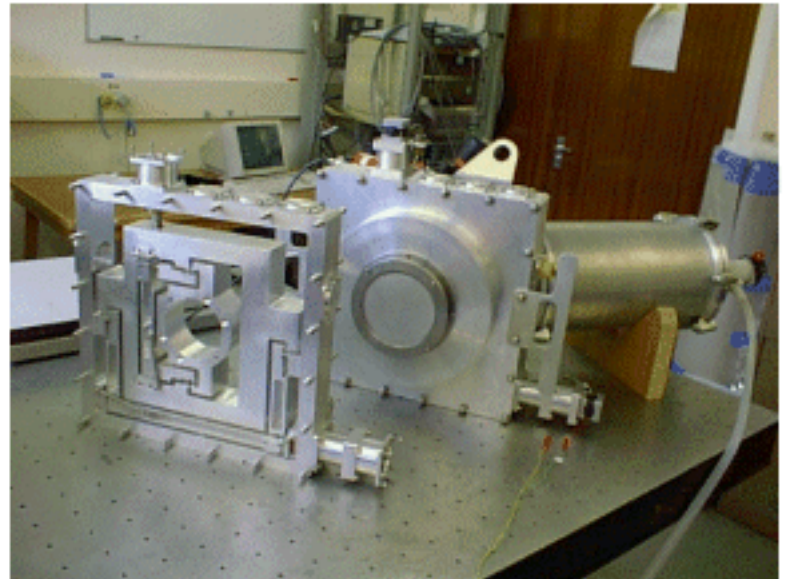
### **UK Progress on GMOS**

The UK work on GMOS is progressing, and we now have pieces of hardware taking shape, both at the

UK ATC and at Durham University.



**Figure 15.** Telescope Simulator modified to accept GMOS and Michelle.



**Figure 16.** x,y,z CCD Translation Stage

In order to prepare GMOS for the flexure rig and subsequent testing, the UK ATC has undertaken major building structural alterations to provide a suitable assembly area for GMOS close to the flexure rig. Structural work has just been completed on the building and the laboratory is currently being fitted out for occupation in June 1998.

Both CCD x,y,z translation drives and all associated vacuum/cryogenic parts are now complete. Both dewars are leak tight and the liquid nitrogen hold times exceed 24 hours. The first unit will be sent, untested, to NOAO in May 1998 to allow engineering grade CCDs to be fitted and evaluated. The second unit will have control software developed during this period. This second, fully tested, unit will be sent to NOAO once the final CCDs are available and this will become the MK unit. The first unit will be returned to ROE for refurbishment and become the CP unit.



**Figure 17.** Filter wheel with motor mounted.

Both shutters are manufactured and results so far are excellent. Tests are continuing with the shutters mounted in various orientations to simulate movements on the telescope.

Assembly work has started on the filter wheel/grating assemblies at Durham. Both MOS's are nearing completion by the manufacturer. It ought to be possible to mount both assemblies on the MK MOS in June 1998.

*-Terry Purkins  
UK GMOS Work Package Manager, UK  
Astronomy Technology Centre*

# **National Project Office Reports**

## **Chilean Gemini Project Office**

**I**tems of interest are:

1. Good progress is being made in the collaborative effort between Chile and Canada towards developing archives for Gemini.
2. Work is in progress with REUNA, a Chilean firm, in order to define and implement the communication system of the Gemini telescope in Chile.
3. The Project Office is engaged in active diffusion of Gemini activities in Chile through various newspaper articles and interviews.
4. Ronald Mennickent, an assistant professor from Universidad de Concepción, was selected for a postdoctoral fellowship at Harvard and sponsored by Fundacion Andes and AURA.

*-Oscar Riveros  
Chilean Project Manager*

# National Project Office Reports

## Brasilian Gemini Project Office

A workshop, entitled "Science with Gemini" was held at Florianopolis, Brasil, from 8 to 10 of December 1997, with large participation of the South-American partners of the Gemini Project: Brasil, Argentina and Chile. The United States was also represented by Robert Kennicut, Doug Simons Phil Puxley, and Robert Schommer. Proceedings, including the description of the projects presented for use of the Gemini telescopes, are being prepared by Beatriz Barbuy, who organized the event. The Proceedings will be released by the end of May.

Other items of interest are:

1. Effective January 1998, the new Project Scientist for Brazil is Reinaldo de Carvalho, from Observatorio Nacional, Rio de Janeiro.
2. Effective January 1998, the new board member for Brazil is Beatriz Barbuy, from Instituto Astronomico e Geofisico, Universidade de Sao Paulo, Sao Paulo.
3. Ronaldo de Souza (IAG-USP) has been awarded an U.S. Gemini Fellowship for the 1998-99 cycle, which he will use to develop post-doctoral studies at the University of Arizona.
4. Effective March 10, 1998, the LNA (Laboratorio Nacional de Astrofisica) has nominated the following members for the "Brazilian Gemini Support Committee":
  - o Beatriz Barbuy (IAG-USP)
  - o Miriani Pastoriza (IF-UFRGS)
  - o Reinaldo de Carbvalho (ON-RJ)
  - o Ronaldo de Souza (IAG-USP)
  - o Thaisa Storchi Bergmann (IF-UFRGS)
  - o Luiz Paulo Ribeiro Vaz (DF-UFMG)
  - o Francisco Jablonski (INPE)
  - o Joao Steiner (LNA Director)
  - o Jose Renan de Medeiros (President of SAB-Sociedade Astronomica Brasileira)

*- Thaisa Storchi Bergmann  
Project Manager for Brasil*

## **News from AURA**

### ***News from AURA***

#### **AURA Awards U.S. Gemini Fellows for 1998-99 Cycle**

On February 4, AURA announced these recipients of U.S. Gemini Fellowships for the 1998-99 academic year:

- Andres Eduardo Piatti of Argentina; Post-doctoral researcher who will be hosted by NOAO/Tucson
- Ronaldo E. de Souza of Brazil; Post doctoral researcher who will be hosted by the University of Arizona
- Ronald Mennickent of Chile; Post doctoral researcher who will be hosted by Harvard University

The program's goal is to strengthen science and technology and enhance astronomy education opportunities in South American Gemini countries. U.S. Gemini Fellowships enable graduate students and researchers from the three South American Gemini countries to study/research at U.S. institutions.

Applications from candidates in Argentina, Brazil, and Chile were reviewed first by committees established by the Gemini national contact offices in each country, respectively. Successful applications were forwarded to an independent U.S. peer review panel for consideration.

Funding for all fellows is provided by the U.S. National Science Foundation. Funding for Chilean awardees is shared by Fundacion Andes of Santiago.

#### **AURA Board and AOC-G Visit Gemini Sites**

On February 24, the Board of Directors toured the Gemini Telescope facility on Cerro Pachón in conjunction with a visit to Cerro Tololo and its meeting in La Serena.

The AURA Oversight Committee for Gemini (AOC-G) toured the Gemini Telescope facility on Mauna Kea on March 15 (before its March 17 meeting). It then visited the Hilo base facility which is also nearing completion. This was the AOC-G's first visit to a Gemini site.

Both groups were impressed with the progress and with the quality of workmanship.





**Figure 18.** Board and AOC-G members at (l) Cerro Pachón and (r) Mauna Kea.

*- Lorraine Reams  
AURA Director of Corporate Relations*

# Released Documents

## Released Documentation





The following documents have been released by the Gemini Project since the last edition of the Gemini Newsletter (December 1997). Copies of these and other publications are available either via Gemini's Documentation page on the Web site at <http://www.gemini.edu/documentation/>; on request by contacting the Gemini Project systems librarian at the project address; or by emailing Ruth Kneale at [rkneale@gemini.edu](mailto:rkneale@gemini.edu). Document numbers are listed in parentheses. **Please note:** This list does not include any Interface Control Documents. For current ICDs, please see the Gemini ICD database tool at [http://www.gemini.edu/systems/icd\\_main.html](http://www.gemini.edu/systems/icd_main.html).

- GNIRS CDR Report. Trueblood, (REV-I-G0118)
- ICS Subsystem Interfaces. Beard et al, Oct 97 (ICD-07a)
- Core Instrument Control System Interface Document. Beard, Oct 97 (ICD-14)
- TCS Beta Review Materials. RGO, Oct 97 (REV-C-G0115)
- "Writing EPICS Device Support". Goodrich, Nov 97 (TN-C-G0055)
- Functional Specification, f/16 Secondary Mirror Tilt System. Roberts, Nov 97 (SPE-O-G0039)
- Bulk Data Transfer Interface Document. Hill/Gaudet, Nov 97 (ICD-03)
- EPICS Synchro Bus Driver Interface Document. Johnson, Nov 97 (ICD-10)
- Standard Controller Interface Document. Goodrich/Johnson, Nov 97 (ICD-13)
- Programmatic Requirements for Gemini Instrument Development. Kurz/Gillett, Dec 97 (SPE-I-G0074)
- Gemini Engineering Archive Requirements. Kotturi, Mar 98 (SPE-C-G0073)
- "The Gemini Observatory Science Operations Plan". Puxley et al, Mar 98 (Preprint #26)
- "The Support Capability Requirements of 8m Telescope Science". Puxley et al, Mar 98 (Preprint #27)
- "Gemini Phase I Science Proposal Entry Tool". Kotturi, Mar 98 (Preprint #28)
- "Design Study of the GNIRS Bracket Structure". Cho, Mar 98 (Preprint #29)
- "Hardware Implementation of the Primary Mirror Surface Heating System for the Gemini 8m Telescopes". Perona et al, Mar 98 (Preprint #30)
- "Infrastructure of the Gemini Observatory Control System". Gillies/Walker, Mar 98 (Preprint #31)
- Visitor's Guide for the Mauna Kea Summit and Gemini Construction Site. Welborn et al, Mar 98 (PG-PM-G0014)
- "Development of Silver Coating Options for the Gemini 8m Telescopes Project". Jacobson et al, Apr 98 (Preprint #32)
- "Measuring Distances Using Infrared Surface Brightness Fluctuations". Jensen et al, Apr 98 (Preprint #33)
- "Characterization of Gemini Near-IR Arrays". Harrison et al, Apr 98 (Preprint #34)

- "Future Gemini Instrumentation". Gillett and Mountain, Apr 98. (Preprint #35)
- "Committee of Gemini Offices Meeting Report." Gillett/Woodsworth, Apr 98. (RPT-PS-G0080)
- "The Ortho to Para Ratio of H<sub>2</sub> in the Starburst of NGC 253". Puxley et al, May 98. (Preprint #36)
- "The Gemini 8M Telescopes Project." Mountain et al, May 98. (Preprint #37)

*-Ruth Kneale  
Gemini Project Librarian*

# Index of /documentation

	<a href="#">Name</a>	<a href="#">Last modified</a>	<a href="#">Size</a>	<a href="#">Description</a>
	<a href="#">Parent Directory</a>	30-Jul-2004 12:35	-	
	<a href="#">acroread.gif</a>	14-Dec-2000 11:59	1k	
	<a href="#">controls.html</a>	09-Jul-2001 07:07	10k	
	<a href="#">documents.gif</a>	14-Dec-2000 11:59	2k	
	<a href="#">documents.html</a>	03-Sep-2000 12:13	3k	
	<a href="#">gsview.gif</a>	14-Dec-2000 11:59	1k	
	<a href="#">icds.html</a>	25-Feb-2002 11:21	7k	
	<a href="#">inst.html</a>	03-Sep-2000 12:13	7k	
	<a href="#">optics.html</a>	03-Sep-2000 12:13	9k	
	<a href="#">preprint.html</a>	17-Jun-2004 11:01	18k	
	<a href="#">preprints/</a>	17-Jun-2004 10:53	-	
	<a href="#">program_guides.html</a>	19-Mar-2003 15:46	3k	
	<a href="#">reports.html</a>	06-Jul-2001 13:43	9k	
	<a href="#">reviews.html</a>	03-Sep-2000 12:13	10k	
	<a href="#">science.html</a>	25-Jun-2001 08:47	8k	
	<a href="#">specifications.html</a>	22-Jul-2002 09:04	8k	
	<a href="#">systems.html</a>	03-Sep-2000 12:13	5k	
	<a href="#">technotes.html</a>	09-Jul-2001 07:07	9k	
	<a href="#">tsbeg.html</a>	03-Sep-2000 12:13	4k	
	<a href="#">webdocs/</a>	31-Oct-2001 09:59	-	

Apache/1.3.12 Server at www.gemini.edu Port 80

# Systems Engineering

## Interface Control Documents Database

---

This section will allow you to query the Interface Control Documents (ICD) database maintained by Systems Engineering. This database will give ICD subsystem and release information. Please select one subsystem at a time to get ICD information on that subsystem, or go directly to the [Reports](#) section. Or, you can check the [status of submitted change control forms](#).

Are you looking for general interface control documents? They can be found in the [Documentation area](#).

### *Abbreviations and codes:*

CON - Controls Group    SYS - Systems Engineering  
OPT - Optics Group    INS - Instrumentation Group  
TEG - Telescope and Enclosure Group

---

Priority codes are determined internally  
by Project Managers.

---

## Subsystem Selection

---

## ICD Reports

[All Subsystems](#)

(Warning - this is a long report.)

[Released ICDs](#)

[Finished \(but Not Released\) ICDs](#)

[Started \(but Not Finished\) ICDs](#)

[Not Yet Started](#)

[Priority Summary](#)

---



---

Virginia Smith / [web@gemini.edu](mailto:web@gemini.edu) / July 25, 2000

# Staff Changes

## *Staff Changes at Gemini*

Many changes in personnel have happened at Gemini since the last newsletter. We have said goodbye to some folks, hello to others, congratulated a wedding, and made a few changes. Congratulations to Jennifer Johnson, who got married and now goes by Jennifer Purcell! We bid a fond farewell to Dick Kurz, Project Manager, who left Gemini in February for a position with ESO. We also say goodbye to Don Ferris, Bret Goodrich, Steve Smith, Mark Warner, and Kathy Wood. We warmly welcome Laurie Bass, Chris Carter, Andy Foster, Tod Fujioka, Pedro Gigoux, John Maclean, Steve Massey, Junichi Meguro, Peter Michaud, Holly Novack, Chase Reed, Jaques Sebag, Marianne Takamiya and John Wilkes to the Project!

Due to Dick's departure, a large amount of reorganization occurred within the Project structure. Congratulations to Jim Oschmann, now the Project Manager; to John Filhaber, now the Systems Engineer, and to Mark Hunten, now the head of a new group, Electronic Systems Engineering. The figure below shows the Gemini project organization as of May 1998.





May 1998

