

J. Stilburn April 9, 2001

## 1. Specifications

### 1.1 Number of sensors and patrol area

The patrol area of the WFS is 2.2 arcminutes in diameter, which is an area 82 mm across. This area is sampled by three probes, each of which can access 75% of the field diameter. The probes are placed 120 degrees apart, as shown in Figure *D* in section 2.3.2.

### 1.2 Accuracy and repeatability of positioning sensors

The probes will acquire an object with an accuracy and repeatability of 15 milliarcseconds, and will maintain this accuracy under all directions of gravity. This translates to an accuracy at the focus of 9 microns.

## 2. Design concept

### 2.1 Choice of detector

#### 2.1.1 Comparison of APD and CCD detectors

The following table compares the relevant characteristics of APDs and CCDs when used in a quadrant detector.

PROPERTY	APDs	CCDs
Thermal and read noise	Zero	~20e/sample at -20C for acquisition, ~5e/sample other
Sky background	2e/msec/quadrant	4.5e/masec/quadrant during acquisition, then 0.2e/msec
Q.E.	Peak 72%. Equal to CCD above 700 nm	Peak 90%
Cost	USD 60K	USD 87K
Capture field	Max 2 arcsec	No limitation
Optics	Complex	Simple
Heat dissipation	60 W	135 W

In summary, a system using APDs is preferred because of the lower noise, expense, and heat dissipation. The QE curves of the two devices are very similar redward from 700nm, with the result that a CCD has more signal from stars of type earlier than K.

### 2.1.2 Detailed characteristics of APD system

The light in each quadrant of each probe will be fed to an APD. The APD is a single-channel module which is fed by a 100-micron diameter fiber and requires a 5 VDC power supply delivering 2 A. The diode element in the module is cooled by a two-stage thermoelectric cooler. Units can be selected for a dark count as low as 25 per second. The dynamic range is large, and the correction factor for non-linearity due to dead time is 1.4 at  $5 \times 10^6$  counts per second. The output is in the form of a TTL pulse for each photon detected, typically 25 nsec wide, and capable of driving a 50-ohm load. To preserve linearity and stability, the case temperature must be kept between 5C and 40C during operation.

The QE dependence on wavelength is typical of a silicon device, peaking at 72% at 700 nm with 30% QE points at 450 nm and 950 nm.

### 2.2 Optical system

Figure A shows the layout of the optical system as it is positioned on a probe. The right angle mirror directs the light from a guide star to a negative lens inside the focus, which changes the f-ratio from 16 to 53. This also changes the plate scale from 0.62 to 2.0 mm/arcsecond. The positions of the negative lenses on the probes arms will vary because of the vertical separation of the probes mentioned in section 2.3.2. The collimating lens straightens the beam just before it encounters the prism, where an enlarged stellar image is formed. Figure B shows the optical system from the collimating lens onward. The light is split into 4 quadrants by reflection from the 4-sided mirror prism having a tilt of 20 degrees on the faces. The light of each quadrant then goes to a parabolic mirror which focusses an image of the pupil onto the polished tip of the fiber. The numerical aperture of the fiber (0.29) and the optical configuration of the telescope permit the transfer of only the light which is off axis by less than 1 arcsecond. Outside of this capture diameter of 2 arcseconds, the beam becomes too steep to enter the fiber.

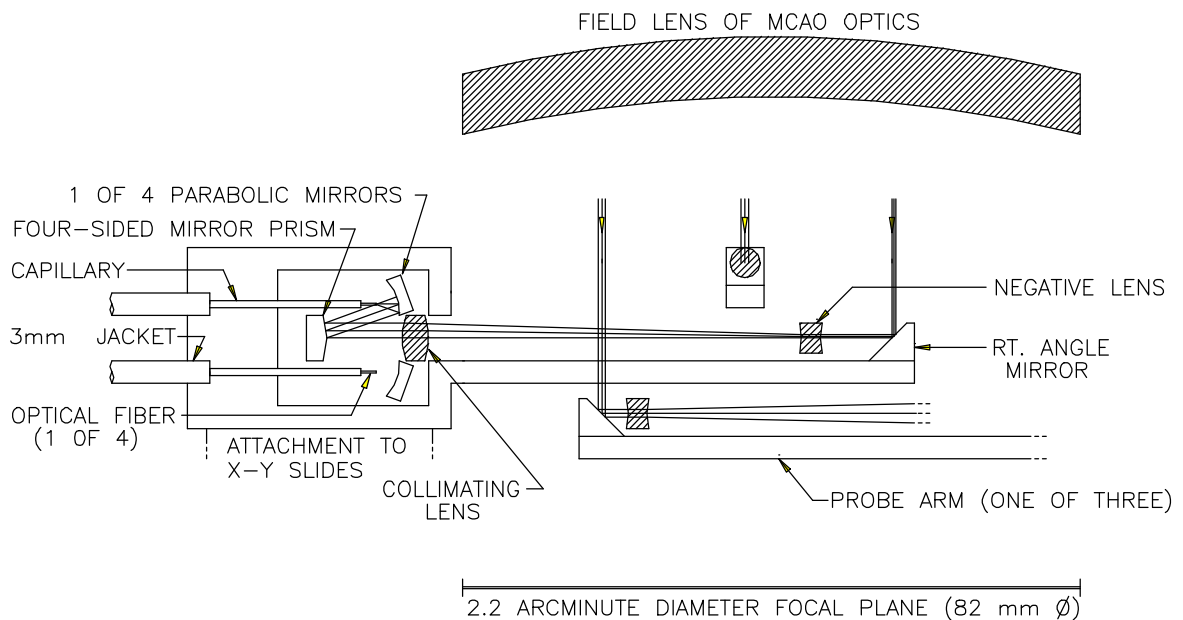

Fig. A. Optical layout. Axial rays are shown for objects 0.5 and 1.0 arcsecond from the axis of the middle probe. Each probe arm is attached to a housing containing the collimating lens, mirror prism, four parabolic mirrors, and four fiber mounts. This housing is attached to the X-Y stage.

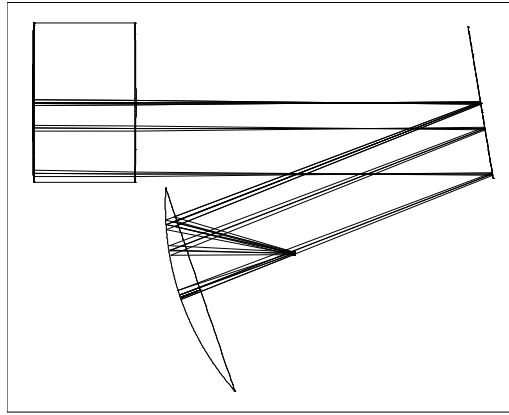

Fig. B. Zemax plot of optical system from the collimator to the focus at the fiber tip. Stellar images are focussed at the mirror prism, and pupil images are formed at the fiber inputs.

All mirror surfaces are coated with protected silver, having a reflectivity over the relevant bandwidth of 96%. All lens surfaces are coated with a broad-band antireflection coating having a maximum reflectance of 1%. The quality of the pupil image on the fiber tip is excellent from 450 to 950 nm, with all of the light from the 2-arcsecond field falling within an 80-micron circle. This allows some small misalignment of the fiber, which has a core diameter of 100 microns.

The fiber is cemented into a 1 mm-diameter stainless capillary tube. The tube bears laterally against two M2 screws which allow a fine X-Y adjustment of the fiber tip to be made. Focus is achieved by moving the capillary longitudinally and clamping it with a setscrew. This is similar to the alignment system used in the successful CFHT SIS guider.

The fiber, which can be up to 1 metre long, is connected to the APD with an SMA connector.

## 2.3 Mechanical positioning system

### 2.3.1 Support and positioning of single probe

Figure C shows the side view of the support and positioning system of a single probe. The length of the crossed-roller slides allows the probe to sample the full 2.2 arcminute diameter of the field in the lateral direction and 75% of it in the longitudinal direction. Because the focal plane is flat and the beam is telecentric, no movement is needed in the axial direction. The slides have a straight line accuracy of 2.5 microns per 25 mm of travel, and a 2.5-micron position repeatability. The load capacity per slide is 275 Kg, and therefore a very small amount of flexure will occur from the weight of the attached lens and fiber assembly.

Each slide is actuated by a precision ball screw assembly. The maximum travel deviation over 80 mm of travel is 8 microns, or 13 milliarcseconds. The ball screw shaft is driven by a servomotor having a 400-line rotary encoder. This produces a movement resolution of 6 microns (10 milliarcseconds). Brakes are not needed on either shaft, as friction is sufficient to prevent back driving of the servomotors while they are unpowered.

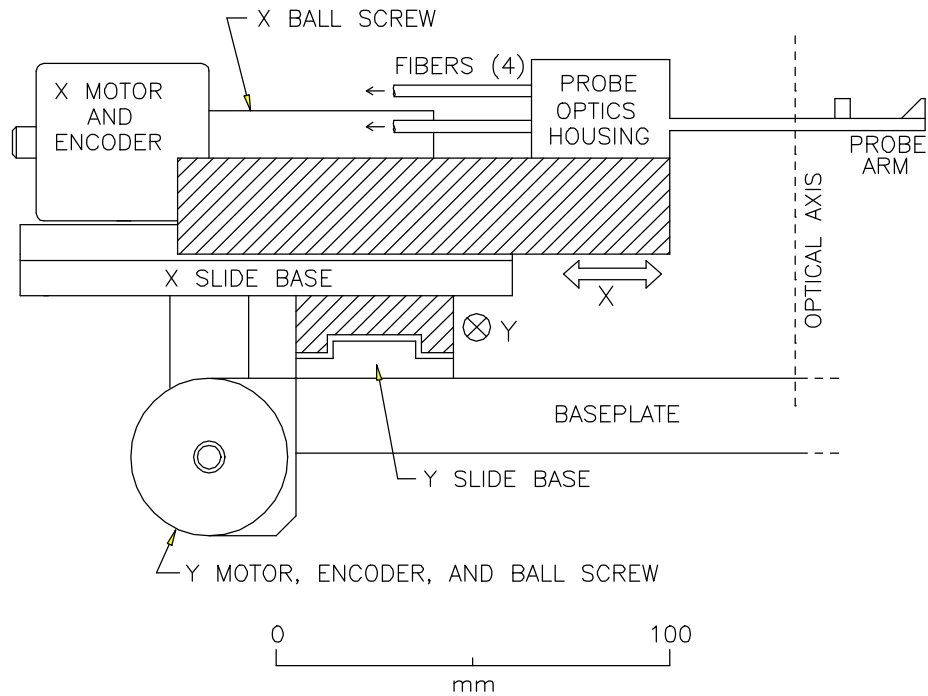

Fig. C. Side view of support and positioning system of a single probe.

### 2.3.2 Integration of three probes

Three probes are positioned 120 degrees apart around the patrol area, as shown in Figure D. The probe arms are stacked vertically with a 10 mm separation to avoid interference. The entire assembly covers a circular area 500 mm across and is 120 mm in thickness in the axial direction. The 12 fibers feeding the APDs allow placing the modules almost 1 metre from the WFS package. Provision must be made for attaching the modules to a heat sink and conducting away the approximately 60 W of heat generated.

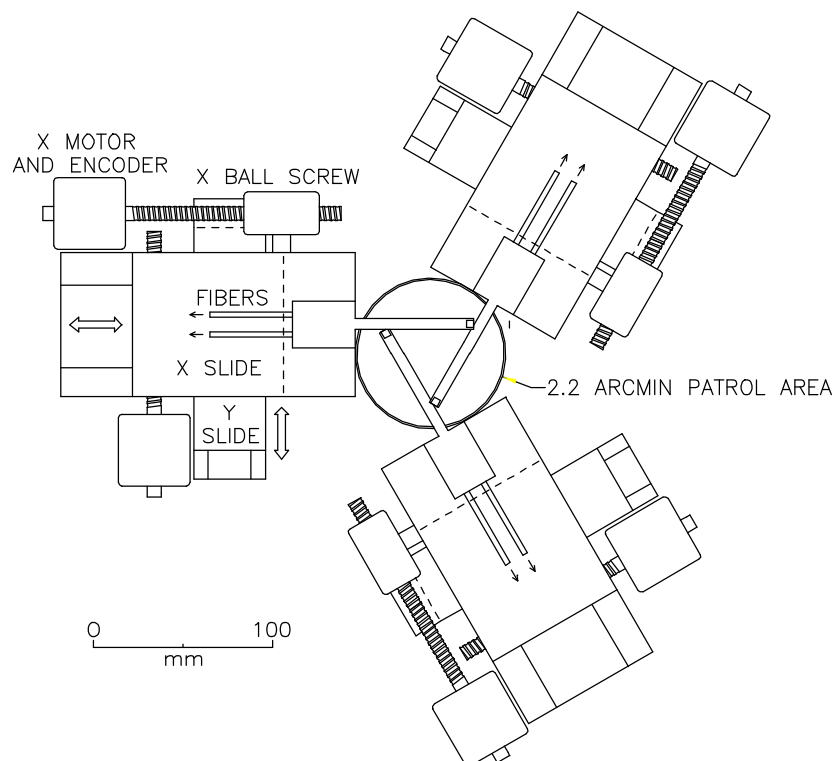

Fig. D. View along optical axis of probes and drive mechanisms.

### 2.3.3 Packaging

The configuration shown in Figure *D* is difficult to package into the volume allocated by the AO Module baseline design. By rearranging the same components, the packaging can be readily achieved. The first two probes are rotated so that they are  $180^\circ$  degrees apart. The last probe, which doesn't need to avoid vignetting the beam, can be moved to be mostly in-line with the beam. Using X-Z stages I lieu of X-Y simplifies the mounting. This configuration is shown in Figure *E*.

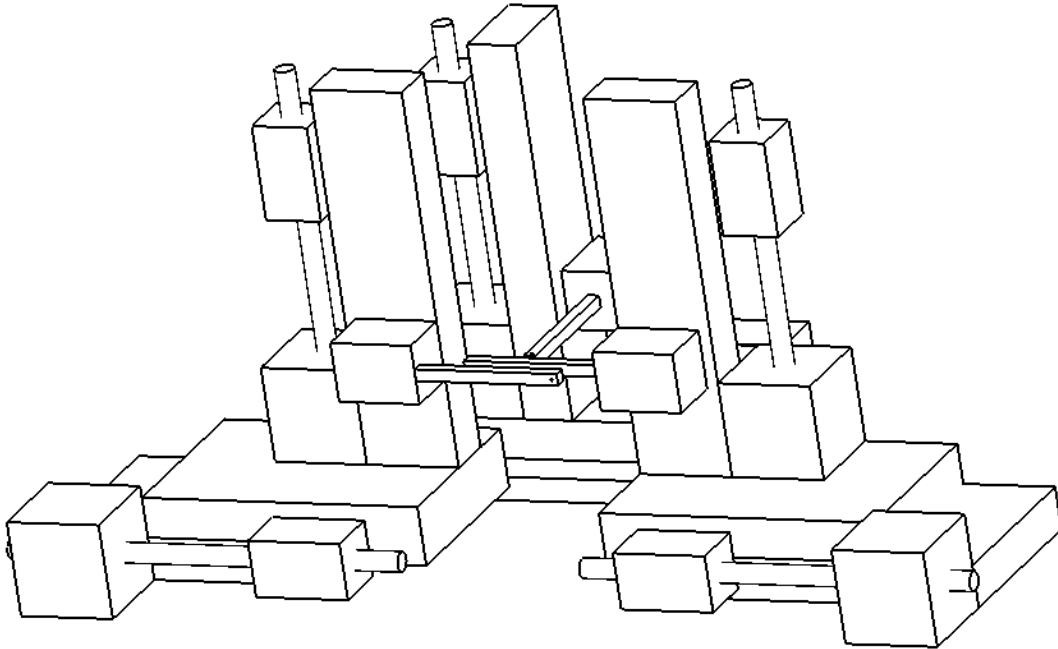

Fig. *E*. View at beam entrance. The optical table (not shown) is at the bottom.